

Rec'd late July '94

SING - LINK

MAY - JUNE '94 VOL 12-3



TORONTO TIMEX - SINCLAIR USERS CLUB

SINC - LINK

MAY - JUNE '94 VOL 12-3

SINC-LINK IS A PUBLICATION OF THE TORONTO TIMEX-SINCLAIR USERS CLUB AND IS ISSUED 6 TIMES A YEAR. CLUB MEMBERS RECEIVE FREE COPIES AS PART OF THE \$20.00 ANNUAL MEMBERSHIP FEE.

NEWSLETTERS ARE EXCHANGED, FREE OF CHARGE, WITH OTHER TIMEX-SINCLAIR USER GROUPS.

PLEASE CREDIT THIS PUBLICATION AND THE AUTHOR IF YOU COPY MATERIAL.

THE TS2068 & ZX-81 GROUP MEETS ON THE FIRST WEDNESDAY OF EACH MONTH AT 14 RICHOME COURT, SCARBOROUGH, ONT. 7PM START.

THE QL SIG WILL MEET AT 586 ONEIDA DRIVE, BURLINGTON, ONT. 7PM START. NEXT MEETING TO BE ANNOUNCED.

SINC-LINK IS PRODUCED ENTIRELY ON SINCLAIR AND TIMEX-SINCLAIR COMPUTERS.

SEND CORRESPONDANCE TO:

SINC-LINK EDITOR, TORONTO
TIMEX-SINCLAIR USERS CLUB, 14
RICHOME COURT, SCARBOROUGH,
ONTARIO, CANADA M1K 2Y1.

EXECUTIVE OFFICERS:

PRESIDENT:
TREASURER:
SECRETARY:
ACTIVITIES:
QL CONTACT:
NEWSLETTER:
LIAISON OFFICER:
(Out-of-town members)

(AREA CODE 416)
RENE BRUNEAU (531-9749)
BILL LAWSON (444-8772)
GEORGE CHAMBERS (751-7559)
LOU LAFERRIERE (820-3725)
HUGH HOWIE (634-4929) NOTE NEW AREA CODE 905
JEFF TAYLOR (244-8583)
GEORGE CHAMBERS, 14 RICHOME COURT,
SCARBOROUGH, ONTARIO M1K 2Y1
(416-751-7559)

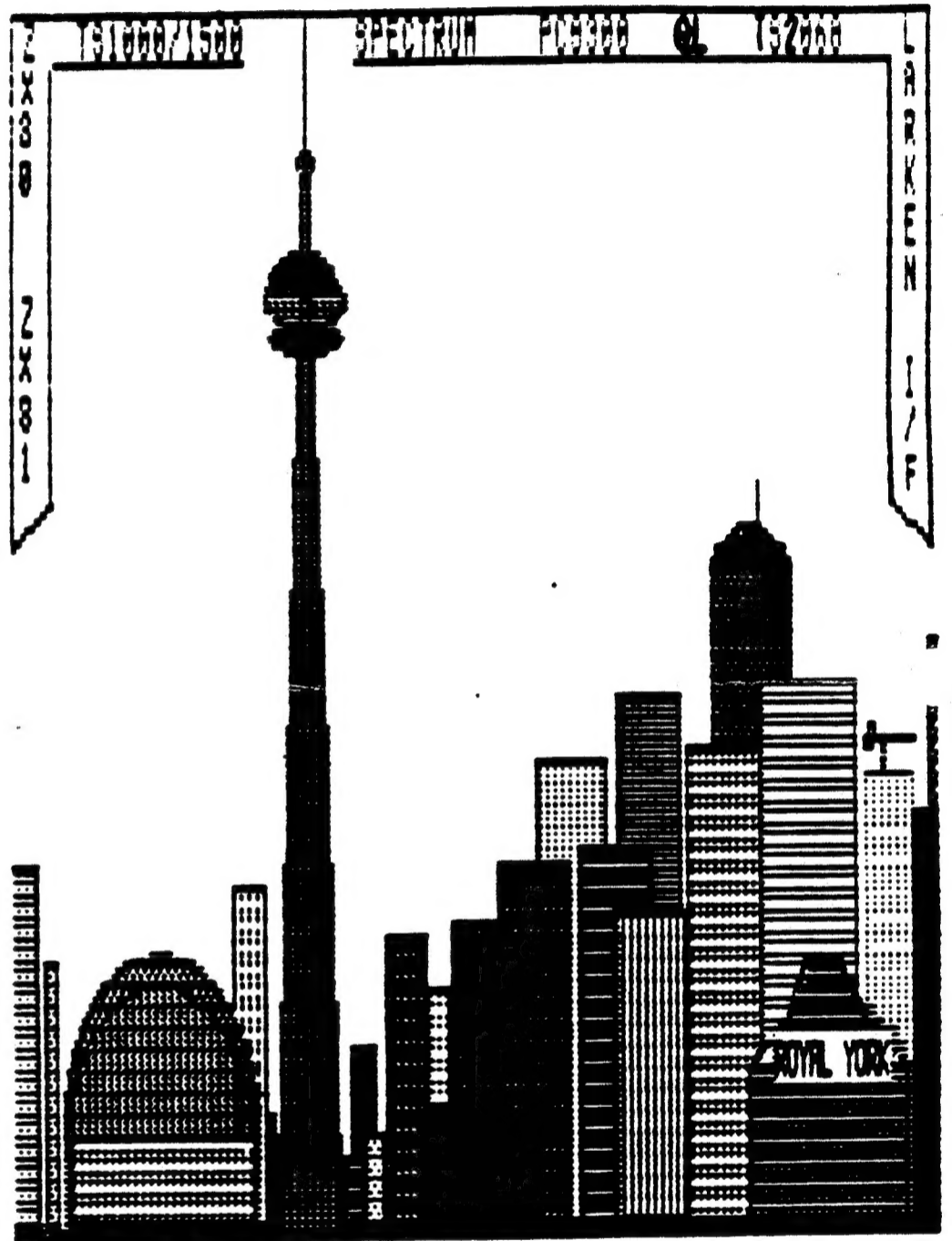

TORONTO TIMEX-SINCLAIR
USERS CLUB

TORONTO TIMEX - SINCLAIR USERS CLUB

**THIS IS THE SECOND-TO-LAST ISSUE OF
SINC-LINK IN ITS PRESENT FORM.**

Now that I've got your attention, I'd like to announce that after the next issue SINC-LINK will no longer be a ZX-81/TS2068/QL newsletter. In fact, unless a whole whack of QLers write to Hugh Howie to continue this as a QL-only newsletter, SINC-LINK will no longer be!!

The reasons? Two, mainly. The first is that there are so few new ZX-81 or TS2068 articles coming in that the newsletter has been coming out later and later as we wait for new material to arrive. Since we've always prided ourselves on trying to present as much new stuff, with as few reprints from other newsletters as possible, it's evident that there just isn't enough interest out there to continue publishing ZX-81/TS2068 articles.

The second reason, the most important one, is that the club executive is worn out. After more than six years as editor/publisher I'm ready to step down. Club secretary/liaison /2068 tape and disk librarian/newsletter mailer George Chambers has had enough after 12+ years of it and the problem is that there is no one to take our places. All the present executive members have been in place for several years and there are no new local members to step in. So after the next issue George and I will not be publishing/mailing any more newsletters.

So what happens now? First of all, let me assure anyone who has recently joined the club as an out-of-town member or who has renewed their membership that your money will be refunded on a pro-rated basis if the newsletter folds.

What? Didn't I just say that it was going to fold? Not exactly.

Hugh Howie is considering the idea of continuing a QL-only newsletter in some form. Since the QL is the only Sinclair machine still being supported by new products and there still seems to be interest in this machine, Hugh feels that the QL users in the club might like to continue getting new articles.

HUGH NEEDS TO HEAR FROM THE QL MEMBERS WHETHER THEY WANT HIM TO PRODUCE A QL-ONLY NEWSLETTER. WRITE OR CALL HIM NOW!

If there is a good response, the club will provide Hugh with seed money to produce his newsletter based out of his home in Burlington, Ontario (just west of Toronto). Those members who do not use QLs will receive their pro-rated refunds and the balance of the club treasury will be donated to local charities as per the club charter.

Next issue we intend to publish a list of all members' addresses and clubs with whom we correspond so you can decide where to go for continuing Timex-Sinclair information.

Hugh Howie's address is 586 Oneida Drive, Burlington, Ontario, Canada L7T 3V3. Phone (905) 634-4929.

Anyone wishing to have an article published in the July - August issue of SINC-LINK should get it to the Scarborough address by the first week of August. That's all for now... J.T.

MIRACLE IN NEWPORT 1994

by Hugh Howie

If you were looking forward to the Miracle in Newport in 1994 you are too late, it is all over and everyone has gone back home - looking forward to next year I would imagine.

On May 12th I left Ontario at such an unearthly hour the roosters were still asleep, headed East through the mountains and the rain, at first a deluge then a steady downpour for hour after hour and mile after mile and road repair after road repair, not to mention the inevitable Toll Booths, until as I approached Newport the rain went off.

As I stepped out of the car at the motel, ten hours and 600 miles after I set out, I was met with a cool Atlantic breeze delicately scented with the odor of the water treatment plant across the way. But I was there, I was in Newport, Rhode Island, I could stop driving and relax. I was ready for what was to come on the morrow.

Friday May 13th.

As the day wore on, I began to see old acquaintances put in an appearance. The LaVernes from Oak Ridge in Tennessee (1000 miles). Jim Hunkins who flew in from California, (the other side of the continent). Paul Holmgren from Indiana, (1000 miles?) accompanied by Tim Swenson of QL Hackers Journal fame. We all got together in my little room for a general chat sharing travelling experiences and other things, and shortly the organiser of the whole affair, Bob Dyl of IQLR (coupla miles) dropped in to inform us he had arranged that we repair to a steak-house for supper. At this time Stewart Honeyball was downtown browsing.

Frank Davis and his wife Carol arrived late in the day, they had come by what was called the "scenic" route, (1000 mile plus scenic!) and had forgotten that "scenic" meant "slow".

Peter Hale arrived late in the evening, he had problems getting out of Boston at that time of day. When he did arrive we had pizza brought in and whoever was there was invited to join in.

John Impellizzeri and Don Walterman

arrived from Michigan in the evening, (800 miles), so another welcoming was held, after which we sort of repaired in dribs and drabs to a place called Crickets, which is well known for its cheer and hospitality and smoke and din. So to bed.

Saturday the 14th day of May, the GREAT DAY, dawned with a clear blue sky, with just a trace of chill in the air. (Don't forget the wafted scented aroma!)

The main meeting was held in the Howard Johnston Motel, and on entering we were greeted with the out-stretched arm of Parker-Lewis saying cross-my-hand-with-silver or the appropriate paper/coinage. Thus did - we could enter the Hallowed Halls of QL Eminence.

On entering the room, I was met with a number of people all smiling and milling around and clutching wallets and whatever else they could place their hands on. I was late in entering as I like to make the grand entrance, (and with my bulk it is not difficult)

Now who was there? There were most of those I have mentioned already. Also, in quick order, Joyce Blaho, Mike Jonas, Gary Norton, all members of NESQLUG, (as also is Peter Hale who was instrumental in the formation of that club). Tom Robbins, Ken Lang and on and on and on.

Later in the day when the hub-bub of buying and selling was on the wane, was the time for Stewart Honeyball of Miracle Systems to start his speil on the Super Gold Card. I guess the problem of bringing into the country, an unknown quantity of saleable merchandise was going to be a bit of a problem, so he was only taking orders, the goods to be shipped when he returns to the UK. Perhaps not the best solution but probably the most practicable under the circumstances. I know that when I entered the States on my way over to Newport, I was questioned very strongly by the border guard about my computer, particularly if any of it was to be sold in the USA, and only the strongest assurances I could give was acceptable.

MIRACLE IN NEWPORT 1994

by Hugh Howie

Anyway, Stewart gave a concise and very descriptive talk and demo on how good this new Super Gold Card really is. I don't know how many were ordered but Stewart appeared to be happy. One thing that is very nice about the Super Gold Card is that Miracle have in-corporated a parallel printer interface into it. Also the extra memory.

Al Boem, a leading light in NESQLUG, gave a very enlightening lecture on the portrayal of Cloud Formations, which is his profession. Very Interesting. (Now how can a portrayal of cloud formations be enlightening, clouds make for dull weather) No-how, Al knows what he is talking about, (he should do, he gets paid for it) and his demo was really "enlightening"

Bill Cable gave a very impressive demo on his business program QLERK. I had previously written a sort of overview of this program, and since that report, he has added a lot of enhancements to the program. Bill has added an unusual touch to the marketing of this program in that you buy the TUTORIAL DISK for \$15, which contains a six page manual to get you started, and if you like what the program does for you, you send him another \$29 for the 130+ page manual that will tell you how to get the most out of your TUTORIAL DISK. In other words, for \$15 you get the lot! but it costs you another \$29 to find out how to use "the lot". If you are smart enough and have enough time, you can learn to use "the lot" on your own, but if you want to go that way, then "be my guest" The manual is worth the little extra it costs. Wonderful marketing idea as the program is really meant to run a small business and/or your home finances, with great detail.

Bob Gilder, was there with his digitiser and gave a very impressive demonstration, showing pictures taken from various sources. You can even use it for pictures from your own VCR if desired. I am not sure, but I think you may have to have a special monitor for greatest value from the unit - perhaps I am wrong. So much going on it was difficult to take it all in.

John Impellizzeri and his partner Don Waltermann had a complete BBS system running between two QL's. They are the operators of QBOX_USA, a new Detroit area BBS that is free to all QL'ers, just the cost of a phone call to Detroit. The BBS is operated entirely on the QL. QBOX_USA is in contact with Tony Firshman's QBBS in England and thus all of Europe.

Of course Mechanical Affinity were strongly represented with Paul Holmgren, and Frank & Carol Davis. They have taken on a few more lines this year and are probably the most aggressive purveyors of things QL in North America.

I was hoping to get a Magnavox RGB monitor from him but he had none left, I even tried to buy his Sinclair monitor but he would not sell it! He is hoping to get more of both, but is not sure if he can do so. I guess that is why he would not part with the one he had.

At breakfast one morning Paul showed me a little black box with a little button on it, and when this button is pressed the unit emits a signal that makes any nearby radar detector think it is entering a radar trap - that should create confusion with speeders. No, he was NOT selling them.

Carol sold a few subscriptions for UPDATE, and Mechanical were also representing Dilwyn Jones who intended to come, but whose employer the Big Bad Corporation (MY words for the BBC - British Broadcasting Corporation) could not let him have the extra few days off. Dilwyn is an engineer (make that high up) for the Western (Welsh) region of that broadcasting conglomerate.

NESQLUG were on the floor, with a very dramatic young man by the name of Fred Jonas (gosh I hope I got that right!) anyway, this young fellow was making like the proverbial fair-ground barker with his come-on chatter. Well done young feller!

NESQLUG had a meeting over the lunch table where the usual club topics were discussed. I was unable to attend as I had promised to be somewhere else at that

MIRACLE IN NEWPORT 1994

by Hugh Howie

Page 3

particular time.

Of course I must not forget to say that Bob Dyl was there doing his best to sell IQLR, the magazine which is the sponsor of the whole thing. Bob being the organiser of the affair was all over the place setting things up and making sure all were comfortable and well taken care of and all needs supplied.

It was regretted by many that Bill Richardson had had to cancel out at short notice. I guess his change of location may have had something to do with that. Tony Firshman was also absent this year. Dilwyn Jones was sadly missed, if there was one common regret it had to be his absence. So many had looked forward to meeting him. Perhaps another year?

The day before I left home to go to Newport, I received a letter asking for a couple of articles from QL World and QL User (now that is going back) and I managed to pick one of them up - so someone is going to be happy.

In talking with Bob Dyl, he mentioned that in 1995 the convention might be held in the Detroit area, thus drawing on a larger area for those wishing to attend. Newport being at the extreme East of the continent, all have to travel considerable distances to get there.

Saturday night will be a night to remember. Many of us assembled for dinner at one of the restaurants on the beach where we had a pleasant meal. It was intended that everyone pay their own way for meal and refreshment, but at the end of the evening the tab was presented as one. Took the restaraunt close to an hour to sort out the individual tabs. No matter, we had a good meal in pleasant company. The extra time was well spent in chat. But we really were tired after a long exciting day.

Sunday May 15th, dawned once again blue sky and cool wind, but that was no matter, as that was the morning Bob was to have a 'hospitality room' in the Motel. Free coffee and donuts. Plenty of both. Plenty of folks. Plenty of good fellowship.

How many attended? a couple or three dozen or so. Not bad for the QL alone, the distances involved, and the fact there was none came from the East other than Europe. You see, all dwellers to the east of Rhode Island use a different kind of computer, they call it fish radar. It is an under water version. Only fish know how to use it. Especially dolphins.

Some QL'ers had gone home, others preparing to do so, among them myself, so I left about 11 am., as I had that long way to go, and yes you might know it, as soon as I left Rhode Island it started to rain, and it rained and rained, and the wind blew, and by the time I got to Utica, New York, I had had enough and called it a day, the journey to be completed the next day, in rain of course, with the wind blowing so strong that, as the old Nova Scotia fisherman would have said, "It took two men to hold one mans hair down".

I have mentioned many names, and I also have forgotten many with whom I had contact. So many bodies all milling around and Peeking and Poking here and there at all the goodies on display. I had my little pocket recorder with me, but with all the excitement and noise of people talking and scuffling about, I am unable to read many of my own comments. Woe is me!

Just think of Jim Hunkins who travelled 4000 (+/-) miles just to be there. Of the many who travelled 1000 miles, but don't forget poor old Bob Dyl who only travelled a couple of miles. Just think of the anticipation of "going somewhere" that poor old Bob missed.

Did I enjoy myself? you bet I did. Were all the other visitors happy? From what I saw and heard I would say that all had a good time, and went home in a happy state of mind with many fond remembrances of people met and topics discussed, knowledge imparted, and knowledge gained. New friends made, and old ones re-established. What a wonderful thing a convention can be.

940519

DID YOU KNOW ? I have been trying for quite a while to verify the schematic that is printed here. I was finally able to verify that my analysis is accurate. It is very difficult to follow all the traces on the chip side of the Larken interface board. I broke a socket when trying to peek under the WD1770 chip. After I found out what I had done I became much more careful - what would I do if I couldn't use my disk drives?

Not shown on the schematic are the +5 connection for the small chips which is on the highest pin number, either 14 or 16. The ground connection is on the opposite corner, 7 or 8.

Please note that data lines D0 thru D5 have two locations so that the schematic would look a little cleaner. The second one is just to the right of the WD1770 outline. Otherwise the Timex edge connections are on the left and the I/F board connections labeled EC1 thru EC34 are on the far right.

Don Lambert probably doesn't realize what a big help he was by writing to me. In my attempt to prepare my reply to him I learned that the chips used on both the interface board and the dock board can't be freely substituted without possible problems. For example I tried to replace the 74LS00 on the I/F with a 74HCTLS00 but it didn't work! Fancier is not always better. Larry Kenny sure knew what he was doing and he did good. Some chips probably can be substituted but I am not enough of a hardware hacker to know when (or why).

I had also seen in the Chicago Area Timex Sinclair Users Group newsletter that you should always use the 1N4148 diodes that come 10 to a package from Radio Shack (P/N 276-1122) and not the bargain package.

Perhaps the best lesson here is that we as TS users need to communicate with each other. WRITING AN ARTICLE FOR OUR NEWSLETTER is a great way to do this. Don's letter solved a years worth of frustration for me, and he didn't even know that I had a problem! In order to continue to improve ourselves we must learn from each other. All the big companies are learning that they need to do this. So should we!

Les Cottrell 108 River Heights Drive Cocoa, FL 32922-6630

LARKEN 2068 DISK INTERFACE

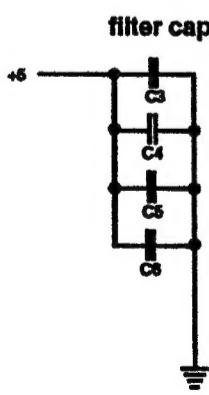
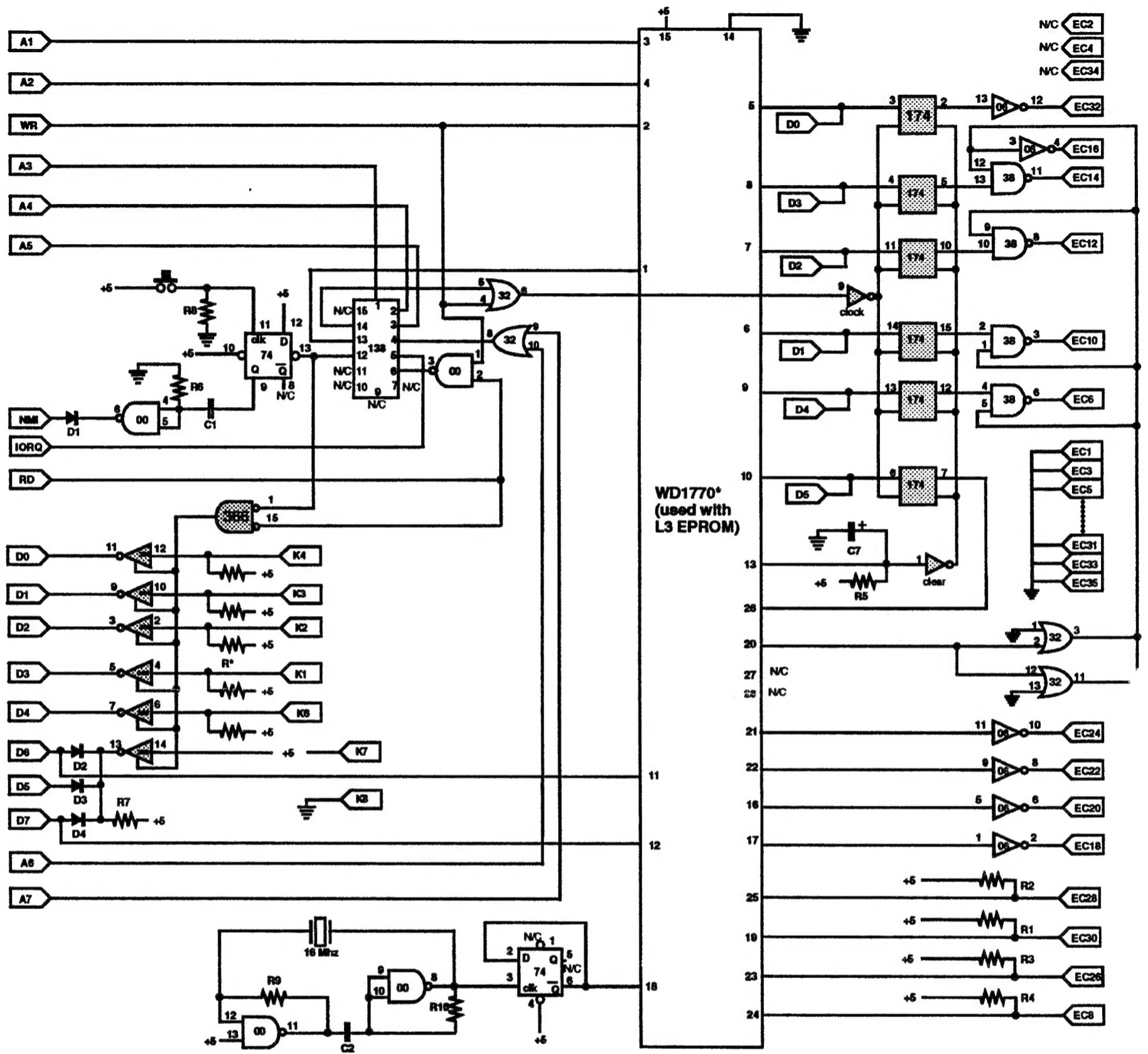

filter capacitors

- between 00 & 74
- between 32 & 1770
- between 1770 & 7406, 7438
- between 174 & disk connector

component	marking	value	chips
R1,R2,R3,R4	R-BK-BN	200Ω	WD1770* 74LS00 7406
R5,R6	BN-GY-R	1800Ω	74HCTLS32 7438 74LS74
R7,R8	BN-BK-R	1000Ω	74LS138 74HCTLS174 74LS366
R9,R10	Y-V-BN	470Ω	
R*		391 x 5 SIP	16 Mhz crystal
C1	102	.001μF	
C2	471	.00047μF (470pF)	
C3,C4,C5,C6	104	.1μF	
C7	22μF, 10v		
diodes	1N4148		* or WD1772 (used with L3f EPROM)

Last issue we dealt with how XCHANGE came to be released to Public Domain. As promised, here is the second part of the article written by Gunther Strube & Erling Jacobsen. Owing to the amount of interest shown in this program it was felt that we were doing a service to all XCHANGE users by publishing this information.

XCHANGE occupies 183K of program space. When it has been read from disc into memory (and has begun to run) It allocates half of the available memory for its working space, but never less than 64K. Letting XCHANGE grab 2MB in a 4MB machine is really not necessary. You can force XCHANGE to only allocate a specific amount of working memory by specifying a parameter:

```
EX flp1_xchange;"120"
```

would allocate 120K of working memory for XCHANGE. With this facility it has finally been possible to control the unnecessary greed for memory of the PSION programs. The QRAM package contained the 'Grabber' utility to control the maximum memory allocation. This is no longer needed with XCHANGE.

The default devices of XCHANGE

The old PSION programs always used a static definition of the default devices, e.g. flp1_ for help information and flp2_ for data files and printer driver information. To alter these parameters you had to use a specific configuration tool and re-save the program file. This is no longer needed with XCHANGE. When XCHANGE is executed it automatically copies the DATA_USE and PROG_USE parameter to the corresponding default data device and help device. If you wanted XCHANGE to fetch its information from particular source on a harddisc, just preset the DATA_USE and PROG_USE parameters before executing XCHANGE. An example:

```
DATA_USE win1_xch_files_  
PROG_USE win1_xch_
```

The above settings would set the XCHANGE default device to win1_xch_docs_ to fetch documents, etc., and set the help device at win1_xch_. During the usage of XCHANGE you can always specify an explicit filename with a complete path specification, e.g. win1_letters_deal2_doc to save the file 'deal2_doc'.

The XCHANGE printer driver

The old PSION program used the printer driver name 'printer_dat' to identify the current installed printer driver. In XCHANGE the name has been changed to 'xchange_dat'. On the XCHANGE program disc you will find a utility, 'Pedit', to modify and create new printer drivers. The file 'Printerset_dat' contains a library of printer drivers. Both an executeable version and source text of the utility is supplied on the disc. The printer drivers is of the same structure as the original 'printer_dat' files. You only need to rename them to be used by XCHANGE. Also included on the disc you will find a utility to display the contents of the current printer driver. The utility is named as 'Prinfo_bas'. In

QUILL one tends to use different printer drivers on the same printer to obtain various effects. We have included a utility to quickly exchange one printer driver with another. Please have a look at the 'Replace_bas' file. The 'Prinfo' and 'Replace' should be compiled to obtain the best results, e.g. by putting them under hotkeys (needs HotKey System II installed).

XCHANGE export/import file format

In XCHANGE QUILL and XCHANGE ABACUS you can export and import files with a special ASCII file format. The commands were implemented to transfer QUILL documents or ABACUS spreadsheets between IBM XCHANGE and XCHANGE on the THOR/QL. The two QUILL documents 'AbacusTransfer' and 'QuillTransfer' describe this format. The ASCII export file format of a QUILL document contains all print types, margin settings, tabulators and text layouts throughout the document. For the first time in the history of QUILL you are able to write a proper translator to import QUILL documents into other wordprocessors like Text87Plus4 or Perfection without loss of the document layout. This one is for you, Software 87 & Digital Precision.

The XCHANGE Task Sequencing Language (TSL)

One of the new features available to users already familiar with the PSION programs is the TSL in XCHANGE. With that you can program XCHANGE to do all kinds of tasks for you with a TSL (command) file. The TSL file is a simple ASCII (text) file that can be programmed in QUILL (then EXPORTED) or your favorite text editor. Provided on the XCHANGE disc is a set of tutorial files which can be used to learn about the various aspects of XCHANGE or for a study of how the TSL files are made. TSL is a powerful tool for the advanced XCHANGE user. Enjoy the tutorials. Unfortunately the 'xchange_tsl' file is missing. Please contact the English XCHANGE User Group (we do not know their address) to get the missing tsl file. They might have more tutorial files for you. Before executing the TSL files you must set the default data device to point at the tsl files. The help device must also be set correctly if you are executing the 'begin_tsl' file. All four XCHANGE tasks have tutorials. An introduction of XCHANGE has been provided in the 'begin_tsl' file. This will at the end automatically call the 'menu_tsl' file which contains a menu selection of which tutorial you might want to execute. To execute a tsl file you must first have defined the default device to the tsl tutorial files. Then activate the <F3> key in the XCHANGE main window to activate the <T>sl command. Specify the filename without the '_tsl' file specifier.

The following is a list of the TSL commands and key codes available in XCHANGE:

TSL key codes:

Many key presses - e.g. ENTER cannot be represented in the simple, direct way. For such cases you use special codes surrounded by square brackets. The full set of codes is shown in the following table. Bear in mind that

each member of the Xchange family does not use every code in this list.

[CR]	Carriage Return (Enter)
[esc]	Escape
[sp]	Space
[f1] .. [f10]	Function key 1 .. 10
[tab]	Tabulator (Tab)
[btab]	Backward tabulator (SHIFT TAB)
[lt]	Move cursor leftward
[rt]	Move cursor rightward
[up]	Move cursor upward
[dn]	Move cursor downward
[wlt]	Move cursor one word leftward
[wrt]	Move cursor one word rightward
[bpr]	Move cursor to beginning of current paragraph (SHIFT up)
[epr]	Move cursor to end of current paragraph (SHIFT down)
[eln]	Move cursor to end of current line (END/ALT right)
[bln]	Move cursor to beginning of current line (HOME/ALT left)
[dlt]	Delete one character leftward (BACKSPACE/CTRL left)
[drt]	Delete one character rightward (DEL/CTRL right)
[dwlt]	Delete one word leftward (SHIFT BACKSPACE/CTRL SHIFT left)
[dwrt]	Delete one word rightward (SHIFT DEL/CTRL SHIFT right)
[dbln]	Delete to beginning of line (SHIFT HOME/CTRL ALT left)
[deln]	Delete one word rightward (SHIFT END/CTRL ALT right)

The TSL commands is available:

&c The remaining text on the line is a comment. The text is ignored when the tsl program is running, e.g. :

&c This is a comment

&d Display text in the XCHANGE control area (top window). E.g.:

&d Press any key

The text will only be shown if the TSL text display is enabled (see &p).

&e The end-of-program statement.
This will terminate the tsl command file status. Control is returned to keyboard command input.

&g Get character - wait until a key is pressed from the keyboard.
The key pressed may be tested by &= .

&i Wait for text to be typed at the keyboard.

The text, terminated by pressing ENTER, is passed to the XCHANGE task. Use this command when tsl is programmed to cater for various input, e.g. typing of files names when XCHANGE prompts for them in activated commands by tsl. E.g.:

[f3]nqui[cr]qtmp[cr]	Create a new quill task	[f3][f3]s[cr]
search from current position		&i
input of string		

&j Jump to the point in the program marked by the following label.

Please note that a label must begin with the '@' symbol at the beginning of the line. With this facility it is easy to implement loops:

```
@loop_identifier
    tsl command ...
&j loop_identifier
```

&p Enables or disables the display of text in the control area (using the &d command). The following parameters is used:

```
&p 1 enables display. This is the intial state of TSL.
&p 0 disables display, allowing the normal control area
contents to be shown.
```

With &p 0 all &d commands will be ignored. &p 1 is also useful just to clear the control area.

&x Wait for predefined letter/symbol to typed at the keyboard. The following parameter would define which key need to be typed for the command to succeed (and TSL to execute the next command). This command distinguishes between upper and lower case letters.

&y Same as &x, but letters are case independent.

&w Wait for the following number of tenths of a second. To halt tsl execution for two seconds use &w 20.

&= c label Jump to the point in the TSL program marked by the following <label>, if the specified character <c> is equal to the one pressed in response to the most recent keypress. E.g. :

&= q quill would be executed to jump to the label '@quill' if the lower case letter 'q' were pressed from the keyboard (using the &g command). Please note the the special key codes are may be used.

TSL labels A label marks a point in the TSL program as a destination for a jump (by a &j or a &= command). The label must start with a @ symbol followed by a sequense of letters defining the label name, and must be the first and only item on that line. You must not include the leading @ symbol when you refer to the label in an &j or &= command.

Symbols The following characters/symbols have special meaning:

& marks a command @marks a program label [starts a special key code]ends a special key code ^the following character becomes a normal one. This allows you to use any of the above without its special meaning:

```
^& ^@ ^[ ^] ^^
```

An example of a TSL program

The following example shows a simple TSL program. You could create the program with almost any text editor, provided that it has the ability to produce a file comtaining plain text, without embedded control characters, and with a LF (line feed) or a CR (carriage return) character at the end of each TSL command line. If you use QUILL to write the

program you should use the Export option of the Files command. Please remember to explicitly specify the `_tsl` extension otherwise an `_exp` is used as default.

```
[f3]neas[cr]Salepc[cr]
&p 1
&d  CST THOR PC with the powerful TSL language
&d  could be used to display sales curves...
&d
&w 80
salgz88=1000+800*cos(cell/4)
[cr]
salgthor=1000+500*sin(cell/4)
[cr]
[f3]v[cr]3[cr]
[esc]
&p 0
[f2]
&e
```

Compatibility of Archive Object programs (`_pro` file format)

The XCHANGE ARCHIVE object file format differs from the original QL ARCHIVE object format. To load QL ARCHIVE programs into XCHANGE ARCHIVE you have load them as ASCII files (`_prg` file format). You can then re-save them with the `<object>` option.

Machine code interface in XCHANGE ARCHIVE

In XCHANGE ARCHIVE it is now possible to execute MC6800 machine code. With this option you have the ability to exploit QDOS from ARCHIVE. This should give you the possibility to use graphics and sound within your ARCHIVE programs. It is interfaced to an ARCHIVE program by means of an additional `usr()` function and a `usr` qualifier to the load program command.

The machine code must be relocatable, that is, it must use only PC-relative addressing modes. In addition to the code, the file must contain a six-byte header. Bytes 0 to 3 must contain "pcm0" and bytes 4 and 5 must be a word given the length of the following code. It is the user's responsibility to ensure that the file has the correct header. The machine code program (in image form, exactly as it would appear in memory) must follow the header, with its entry point at the byte immediately following the header. The code must end with a return from subroutine (RTS) instruction.

To load the machine code module into XCHANGE ARCHIVE, it is necessary to use the load command:

```
load usr <s.expr>
```

where `<s.expr>` is a string expression which evaluates to the file name. Unless an extension is explicitly included in the filename, the default extension of `_pmc` is assumed. After having been loaded, the machine code may be executed with the numeric function:

usr(<n.expr>,<s.expr>)

The first argument is converted to an integer and loaded into register d0 before jumping to the entry point of the machine code. You may use this value in any way you please but the the intension is to provide a facility to vector one of a number of different routines in the machine code. In this sense the argument becomes a function number. The second argument is a string expression which must evaluate to the name of an existing ARCHIVE string variable. All XCHANGE ARCHIVE string variables have a leading length byte. The usr() function transfers the address of this length byte to address register A0 before juming to the code.

After having allocated a string variable, e.g. a\$, the corresponding usr() call might be:

```
let res = usr(2,"a$")
```

On the return from the machine code routine, the contents of register d0 are converted to ARCHIVE's floating point form and returned as the value of the usr() function. The second argument can clearly be used to pass information in either direction between ARCHIVE and the machine code routine. It is your responsibility to ensure that the machine code does not write to any memory location outside the region allocated to the string (the length byte should be regarded as being outside this region). The machine code may make free use of the registers; the usr() function preserves and restores all registers automatically across the machine code.

It is not possible to specify exactly the space available on the stack, but it will typically be of the order of 1K. You should therefore avoid excessive use of the stack, such as for large buffer areas or for heavily recursive processes.

The following is an example of how to have a 32K binary startup screen for an ARCHIVE application:

```
HEADER:      DC.B      "pmc0"
              DC.W      SCRDATA - START + #32768 ; code & screen image

; Machine code to move image to screen memory
START:      MOVE.L    #131072,A0          ; A0: ptr to scr. memory
              LEA     SCRDATA(PC),A1      ; A1: ptr to scr in buffer
              MOVE.L   #32767,D1         ; D1: size of scr. LOOP:
              MOVE.W(A1)+,(A0)+         ; move image to scr memory
              DBRA    D1, LOOP
              RTS                       ; Return to ARCHIVE.

SCRDATA:      DS.B      #32768           ; screen image from here...
              END
```

As seen in the above source text it is necessary to store the screen image right after the machine code. The code is then saved as a whole, ready to be loaded into ARCHIVE (machine code + 32K).

END

The ZX Printer and its Paper

by Gil Parrish

One of the problems in keeping old computer printers up and running is finding the supplies. Replacement ribbons can be difficult to locate for particularly obscure units; but, even coming up with the paper for models using something other than the ordinary 8½" wide variety (9½" wide for tractor feed models, given the extra 1" for the sprocket hole strips) can be an effort. Several old TS/ZX printers happen to use narrow roll paper of some kind. For the dot-matrix Mindware MW-100, 1¾" adding machine paper is still available through office supply stores; for the T/S 2040 thermal printer, 4⅞" thermal paper is still available through Radio Shack (Catalog 26-1332, for 2 rolls of 80'). But where exactly do you find the 4" metallized electrosensitive paper needed by the Sinclair ZX Printer?

For those who are not familiar with it, the ZX Printer is a device designed in 1981 by Sinclair to be a low-cost peripheral for the equally-thrifty ZX-81 computer. It has a rectangular case of black plastic just 5½" wide by 2¾" long by 1¾" deep, though the 4" wide paper roll creates a slight bulge on the back. It has no electrical cord, and instead gets its power from the ZX-81. (It requires the ZX-81 to have a stronger-than-normal power supply, namely 1.2 amps.) Its connecting cable (with passthrough connector) is only about 4½" long. It frankly looks like a toy, especially when placed next to a serious printer.

It utilizes an electrostatic dot-matrix print process, in which the two separate printheads (on a continuous belt) are not considerably more evolved than "spark plugs". To work, this process requires a special paper with a metallized coating (typically aluminum or cadmium, and light silver in color) on top of a black layer. There is no ribbon; instead, the printheads just pass continually across the paper electrically discharging at the desired spots, thereby vaporizing tiny dots of the metal coating to allow the black layer below to show through. The printheads take 6 passes across the paper to print a single line before stopping, letting the paper advance more, and starting the next line. This takes a while, even though the printheads move quite rapidly. The resulting 6x6 uppercase-only letters are rather large-- far more sizable (at about 4½ lines/inch and about 3⅝" wide for 32 columns) than on a 2040 (perhaps 8½ lines/inch and about 3⅞" wide for 32 columns)-- and perfectly readable, even though they appear rather insubstantial and even rather ghostly on their silvery background.

While the electrostatic process was not unique to the ZX Printer-- several early printers used it, including full-width printers-- such process is no longer used in the computer world. So for the ZX/TS enthusiast who owns a ZX Printer, the question becomes, where can the paper be located? When I asked this question, several people mentioned good old Radio Shack ("RS") as a vendor of such paper. From what I discovered in old catalogs, RS made two printers that used an electrostatic print process-- the "Quick Printer" and the "Quick Printer II". The Quick Printer used paper 4¾" wide; RS sold it in packages of 3 rolls of 130' (Catalog 26-1405). The Quick Printer II used paper only half as wide (2⅜"); RS sold it in packages of 2 rolls of 75' (Catalog 26-1412). Since "genuine" ZX paper seems to be between 3⅞" and 4" wide, I am not sure if ZX users who bought RS paper typically chose the 4¾"

paper and cut it down to fit (such paper could not be shoehorned into the ZX Printer uncut), or if they chose the 2 $\frac{3}{8}$ " Quick Printer II paper and lived with the decreased size. The catalogs showed prices for metallized paper increased continually at RS over time. Quick Printer paper that was \$16.95 in 1984 (about 11 cents per square foot) was \$24.95 in 1989 (about 16.2 cents a sq/ft); Quick Printer II paper that was \$3.95 in 1984 (about 13.3 cents a sq/ft) had more than TRIPLED in price by the 1992 catalog (\$11.95, over 40.2 cents a sq/ft). I guess RS, as the sole continuing vendor, had no incentive to keep down prices.

Anyway, I called local RS stores to place an order, and was told both papers are no longer available. The Quick Printer paper does not even show up in their computer system, and the Quick Printer II paper is shown as having been discontinued in March of 1993. I received more discouragement when I checked local stores to see if I might happen to stumble on some leftover rolls gracing a corner; none of the stores I visited had any at all. I discovered you can telephone a local RS, that store can call the district office, and that office can run a computer check of shelf inventory for all stores in the district. However, what shows up on the computer does not necessarily match actual inventory. I was assured one nearby store had several packages, yet encountered only blank looks when I arrived at the indicated locale to purchase some.

But all is not lost for the intrepid ZX Printer owner; I happened to hit paydirt on my last try. I called the RS mail order service directly (in the U.S., 1-800-223-8344), and was told the 2 $\frac{3}{8}$ " Quick Printer II paper remains available as a "special order" item (still Catalog 26-1412, and still \$11.95 for a two-pack of 75' rolls). I ordered a package, and found the 2 $\frac{3}{8}$ " paper can be used by itself in a ZX Printer, if you can live with the decreased width. If you cannot, two narrow strips can be taped together to create a wider roll. Step by step:

- (1) Cut off two lengths of the paper. These can be any length you need for your particular print project, but shorter lengths (2' to 3') seem to be easier with which to work.
- (2) Lay the strips side by side, shiny silver side down, with weights periodically along their length to hold them in place. Close the seam between the two as tightly as you can.
- (3) Get small (say, 6") strips of transparent tape and stick the seam together. In theory you could use one continuous strip of tape, but in fact that seems rather hard to manage.
- (4) Now that you have paper 4 $\frac{3}{4}$ " wide, you must cut it down. You need to cut $\frac{3}{8}$ " off each side; experimentation indicates you CANNOT simply cut $\frac{3}{4}$ " of one of the sides and have the resulting paper print properly on both sides of the seam. If using a paper cutter, put the seam on the 2" mark and start the slice; you'll need to move your hand several times to keep the paper in the correct position for the entire slice. The paper can then be flipped over, the seam again placed on the 2" mark, and another slice taken. If using scissors, place some pencil dots on the back of the paper measured out the proper $\frac{3}{8}$ " distance from each edge, use a ruler to draw a pencil line connecting the dots, and then cut along the line.

This process is not a piece a cake, and you may have to practice your technique a bit to get good paper. But at least the resulting product is fully serviceable in your ZX Printer.

DID
YOU
KNOW

THE 2068 TEACHES SUNDAY SCHOOL!

I teach a class of fourth, fifth and sixth graders. Some time ago I promised that I would bring my computer in to class. Since I built a second interface to prove that I had the schematics correct I was now able to bring two 2068's to the class. I was afraid that only one keyboard would not keep everyone busy. I modified the normal lesson material to run on the computer. This one started with a game that looked suitable for computerizing. My only problem was that I haven't done much basic programming recently. The trick to the little game is that "Hanna" only likes things that have double letters in their name. So all that was required was to check for two adjacent and identical characters. (It is a cute game and I thought that some of you might have children or grandchildren that would enjoy it.) I fumbled around and came up with the code in the listing printed here. It works well enough to have been quite successful in class. It can be fooled by any double entry - two spaces, two commas etc. I told the class to only input real words and they didn't try to cheat. I was afraid that having the samples on screen would make the solution too obvious, but that was not the case. None of the students figured out the trick on their own.

A correct word gives a sort of "purr" and a smiley face. A wrong answer gives a beep and a sad face. Only the first couple of lines of the user designed graphics are shown, but I had to look up the scheme before I could remember how to do them.

If anyone else tries this, here are my "lessons learned". The story was read together by scrolling through with the built in scroll. One student held down the enter key and scrolled all the way to the end - and they can't read that fast. After each screen is displayed I should have asked a question pertaining to the material on screen. For example INPUT "who said...";q\$.

At the end of the story and enough discussion to show they got the point I gave them the password to move on to a game of "Diamond Max". One computer had four students and the other had three and they exchanged places at the keyboard after they lost two men. They enjoyed using the computer enough that even my 'trouble maker' was well behaved!

MScript TIP If you have ever tried to print or save after editing only to find that your last change wasn't there here is why. Function-Q is the MScript version of UNDO. If you haven't moved off the last line you edited you can press 'Function' Q to return the line to it's former condition. All changes are held in a "change buffer" until you move from that line so UNDO can work. So, ALWAYS move the cursor up or down prior to saving or printing.

Les Cottrell 108 River Heights Drive Cocoa, FL 32922-6630

The 2068 teaches Sunday School listing

```
1 GO TO 1000: REM user defined graphics - a smiley face or a
sad face
5 POKE 23658,0:BORDER 7:PAPER 7:INK 0
10 CLS : PRINT "We'll start with a game of 'Happy Hanna'. When
you guess why she likes some things and not others, don't tell
anyone, it will spoil the fun!"
15 PRINT
20 PRINT "Happy Hanna likes puppies, but not cats."
25 PRINT "Happy Hanna likes summer, but not spring."
30 PRINT "Happy Hanna likes kittens, but not dogs."
35 PRINT "Happy Hanna likes teenagers, but not adults."
40 PRINT "Happy Hanna likes racoons, but not goats."
50 PRINT "Happy Hanna likes butterflies, but not insects."
60 PRINT "Happy Hanna likes caterpillars, but not worms."
100 LET k=0 : LET m=0 : INPUT "She likes..";a$
105 IF a$="advance" THEN GOTO 200: REM password to next part
120 FOR k=1 TO LEN (a$): LET m=k+1
121 IF m-1=LEN a($) THEN GO TO 140
124 IF a$(m) =a$(k) THEN FOR x=0 TO 2 STEP .2: BEEP .02,x: NEXT
x: FOR x=5 TO 0 STEP -.5: BEEP .02, x: NEXT x: PRINT AT 20,
22;"#a": PRINT AT 20, 23;"#b": PRINT AT 21, 22;"#c": PRINT AT
21, 23;"#d": GO TO 100 140 NEXT k
141 BEEP .1, .8:REM fail
150 PRINT AT 20,22;"#a"
160 PRINT AT 20,23;"#b"
170 PRINT AT 21,22;"#e"
180 PRINT AT 21,23;"#f"
199 GO TO 100
200 CLS : PRINT "No one likes to be an outsider. Share with
your team some time when you felt left out.": PRINT : PRINT :
PRINT
210 PAUSE 888: PRINT "Press 'ENTER' when you are done.": PAUSE
0
220 CLS : PRINT "Acts 10:34-35": PRINT
230 PRINT "Then Peter began to speak to them: 'I truly
understand that God shows no partiality, but in every nation
anyone who fears him and does what is right is acceptable to
him.'"
240 PRINT : PRINT : PRINT "What does 'partiality' mean? When
you have decided, tell Les."
250 INPUT "....";b$
260 IF b$="biased" THEN GOTO 300: REM password to next part
270 GO TO 250
300 CLS : PRINT : PRINT "Read this story together. Press ENTER
to scroll to the next page."
310 PRINT : PRINT : PRINT "A mind expanding trip": PRINT :
PRINT " The sun was setting as Peter climbed the steps at the
side of the house and walked out onto the flat roof. He gazed
thoughtfully toward the sunset and realized that chapter in his
life was coming to a close."
.
.
1000 POKE USER "a"+0,BIN 00000111
1010 POKE USER "a"+0,BIN 00011000
etc.
```

NOTE: "#a" means graphic a

Friday, May 27, 1994

Dear Hugh,

Enjoyed your two articles in the last Sinc-Link.

With the addition of a screen dump, the QL takes on an IBM-like capability available through SHFT-PRINTSCRN.

However, I think that the QL's screendump is superior in that it's a bit-mapped printout whereas the IBM version is character based. In other words, the QL screendump is always an accurate rendition of everything one sees on the monitor, pixel for pixel, while some IBM outputs print garbage simply because no character exists to depict what is actually shown on the screen.

Lastly, programmers for IBM-like machines may be able to disable the SHFT-PRINTSCRN function in their applications whereas I believe the QL screendump is always available to the user.

George Chambers' request for information on Clive Sinclair brought to mind a TV program I've seen within the last few weeks, it may have been a PBS presentation. There was Sir Clive, explaining his latest endeavor, a re-chargeable battery powered bicycle, in living color! - Sir Clive, that is, the bike is - what else? - black!!!

I have to conclude that the financial drubbing he took on his electric car seems only to have whetted his appetite to bring electrified locomotion to the planet.

As I recall, the interviewer did not let on that she was all that impressed with the bike but she did opine that it was "cute!" My only other recollections are that the bike was small and went quite fast - downhill! If he's offering a Pentium-plus for \$25 - Canadian or US? - it was not mentioned.

As Mr. Chambers has been mentioned, perhaps in the not to distant future he would favor Sinc-Link's readers with a list of the things he can now do with his 486 that he couldn't do before or as well.

A thought occurred the other day which may be of interest. It has to do with using the obligatory F1/F2 start-up keypress for selection of an option OTHER than Monitor/TV mode.

In going through some old QL literature I found that the selection of the F1/F2 startup keypress can be detected by PEEKing memory location 163890. If F1 had been pressed, PEEK(163890) = Zero and for F2 the result would be 2, on the JSU rom.

This bit of information combined with the Toolkit II commands, WMON and WTV, available to Trump and Gold Card owners, combine to allow an alternative use for F1/F2, e.g.

```
10 TK2_EXT(FLP_EXT) : IF PEEK(163890)=2 : WMON : GO TO n
```

WMON resets the screen to Monitor Mode if F2 had been pressed. If one uses a TV, PEEK(163890) would be looking for Zero, the F1 keypress, and resetting would be to the TV Mode via WTV.

"GO TO n" is illustrative only, one may substitute a Procedure call or any other desired course of action.

One use I've found for it is in our wordprocessing application. In addition to Quill, I've installed a number of other options to load such as, a SuperBasic program to download files from our Laser PC3 computer, FlashBack, QWriter, and SpellBound.

Each of those options is used occasionally but more often than not just getting Quill up and running as soon as possible is the goal. Therefore, our BOOT file was configured to allow bypassing of all options with an a\$=INKEY\$(-1) keypress, e.g. "Press 0 for Options." "0" would allow proceeding through all of the options serially while any other keypress would immediately bring up Quill.

The utilization of F2, PEEK(163890) and WMON now allows selection of Quill with no options before start-up with the added benefits of eliminating both the pause and the second keypress. Pressing F1 simply runs the program in the manner in which it ran before the change. Pressing either F1 or F2 maintain the QL in the monitor mode.

It's not a revolutionary breakthrough, just another incremental change which may help with a problem or spark a better way.

Trust that most of your snow has melted and that horrible US weather you've been getting has abated.

john (Juergens)

That last comment about the weather is a gentle reproof from John for what I had said to him about our Toronto weather, that according to the radio reports, many of our winter storms start in Texas and reach us via the Ohio valley.

In a subsequent letter, John asks why George Chambers went the way of the "Blue Blaster" ~~for~~ not QL. John feels that a letter from George to Sinc-Link on this subject might be of considerable interest, as John has tried both and is of the opinion that the QL does most of what the average user might require from a computer. Quote "The QL is NOT the ultimate in computers but the performance/cost ratio is so much higher than anything else I've ever seen and it switches tasks so smoothly that, like yourself, I doubt I shall need more"

Have you any comments to George?

Hugh H. (940616)

Last year, when I was trying to figure out how to convert an IBM program to Sinclair BASIC for my 2068, I wrote a letter to Alan Pywell to ask him how to he would convert the following IBM line...

```
ON RO GOSUB 1100, 1140, 1200, 1350...(etc.)
```

I thought I had found a fairly good solution. I believe I used IF statements (IF RO=1 THEN GOTO 1100, etc.) but Alan Pywell had a much better way of doing it. Actually a couple better ways. The rest of this article is from his letter...

```
-----  
ON RO GOSUB 1100, 1140, 1200...etc.
```

This is basically a "calculated Gosub," since the computer has to calculate the destination. The good news is "our" computers also do calculated Gosubs--the only (slight) difference is that the destination numbers must be equally spaced (a way round this follows shortly!). I will write as if your knowlede is zero--forgive me if I state the obvious occasionally as this is better than leaving out a snippet of vital info! "Our" calculated destinations also differ from those on lesser computers because we can tell the Spectrum or QL what the calculation is to be. Lesser BASICS "expect" a line number and complain if they don't get one. "Our" machines don't "expect" anything--they always call a "full-expression evaluator" to sort out the destination. Thus GOSUB 1000-(10*XY)+A/B is a legitimate command. Incidentally, it is this full expression evaluator that helps to make Sinclair BASICS relatively slow. Another legitimate command is GOSUB 5000+RO. Thus:-

```
100 GOSUB 5000 + RO  
110 ---  
120 --- etc.
```

```
5001 PRINT "This is Room 1: RETURN  
5002 PRINT "This is Room 2: RETURN  
etc.
```

There is the problem that the line numbers you quoted are not evenly spaced. If you cannot juggle the line numbers so that PRINT lines are evenly spaced then you need to read your line numbers from DATA statements. We now make use of the full expression evaluator to calculate a line number for RESTORE.

```
100 RESTORE 6000+RO  
110 READ X  
120 GOSUB X: REM X=5000 or 5050 or 5110, etc., etc. depending on  
value of RO
```

```
5000 PRINT "Room Number 1" : RETURN  
5050 " " " 2" : "  
5110 " " " 3" : "
```

```
6000 DATA 5000 : REM READ LINE NUMBERS TO GOSUB TO  
6001 DATA 5050 (copy these numbers from the original  
6002 DATA 5110 ON RO GOSUB)
```

Reading the line numbers as above is somewhat cumbersome really (ask a purist!!) but it greatly simplifies translation from other BASICS, and it works! Of course, if you're writing a program from scratch, just ensure that your GOSUB destinations are evenly spaced. They don't have to be separated by 1, as above, you could separate them by say 10, or 100.

```
GOSUB 5000 + 10 * RO (5010, 5020, 5030, etc.)
GOSUB 5000 + 100 * RO (5100, 5200, 5300, etc.)
```

Having said all that, when writing an adventure game from scratch, don't use a PRINT line for every room -- you'll have the purists howling for your blood! This is the method I used to use on the Spectrum. Somewhere in the start-up routine, DIM a string array to the number of rooms by the length of each room description, i.e. DIM R\$(19,32) would allow for 19 rooms each with one line of text. DIM R\$(19,64) would allow for two lines of text. PRINTING a room description requires a mere one line:

```
100 PRINT R$(RO, 1 TO) <-- this looks strange but it works!
```

So, how to put the descriptions into R\$? Put them into DATA statements than READ them is the obvious answer. But on the Spectrum I was always short of RAM space, so why store the text twice? (Once in R\$, once in DATA statements.)

I used to enter the description in direct mode (i.e., omit line number) as I needed them. For example, say I've written the adventure to ROOM 10. Now I want to "do" ROOM 11. I would type LET R\$(11)="This is ROOM 11" -- with no line numbers. To test, type PRINT R\$(11, 1 TO). (The "1 TO" may not be necessary on the Spectrum, I can't remember.)

When you save a Spectrum prog the variables are saved also. BUT -- don't use RUN or NEW! Use GOTO 1 or whatever, or your variables, including room descriptions, will be wiped out. If you're not short of RAM space, use DATA statements, as in the following method, which I use on the QL.

```
100 RESTORE 28000 + RO
110 READ room_desc$ : PRINT room_desc$

28001 DATA "This is Room One"
28002 DATA "This is Room Two"
      etc.
```

You can also use this method for object descriptions. It is very easy to implement long and short descriptions -- let me know if you want more info.

*Alan Pywell's address is -- 13 Sandyfields Close -- Sea Lane,
Saltfleet -- Lincolnshire -- LN11 7RP -- England {copied by R. Blizzard}*

Mar/Apr 1994

May 6, 1994

Dear Out-of-Town Members,

Well, I've gone and done it. I've bought an MS DOS machine, and I'm revelling it it! In fact I'm using it to write this letter. It is a 486DX33, with 8K RAM, a 340M hard drive, 2 floppies, and a modem.

What I have done is move the Timex to my basement workshop adjacent to the playroom. Last night we had a TTSUC club meeting at my home, and simply opened a connecting door to access the TS2068 computer setup. Works quite smoothly.

I had a letter from David Lasso recently, asking about the transfer of variable between a controlling Basic program and an associated TIMACHINE-compiled code block. Some of you might be interested in this so I shall just mention that it can be done. Here's how.

When you compile with TIMACHINE, ask that it print out the address locations of the variables in the compiled code. Then, in the Basic program you can PEEK and POKE to these addresses to move the variables around. I think that Bob Mitchell probably wrote an article on the subject for a past newsletter. I worked with Bob on this subject many years ago when we were developing a program to index disk programs. I'll go to the Timex and look it up right now!!

I have found an article by Bob Mitchell, in the Nov/Dec '87 issue on page 6. It describes this peeking and poking of variables between a basic program and Timachine compiled code. Interested? Ask me for it.

A question was asked last night, at our club meeting, whether anyone had heard news about Clive Sinclair. No one had, but coincidentally, a few minutes later a member arrived with a news clipping. It said that Clive Sinclair had come out with a new computer chip which had a higher speed rating than the Pentium, but which would only cost about \$25. Well, we'll see. Maybe it is true; maybe it's pie in the sky.

While I was looking up the item on Timachine I came across another article by Bob M. on how he downloaded files from his Timex machine to his MSDOS machine. Lucky me, since I want to load some of my Timex text into the new machine also. He used a direct null modem connection. I think I am going to do it an easier way. My son has his own phone in the house, and I'll simply connect the Timex to his line and call it up that way.

Any members waiting for anything from me? I think I am up to date. Do drop me a line and remind me if you are waiting for anything. Also, do look at your mailing label to see whether your membership has expired. I circle the expiry date on the label with a red pen to remind you. watch for it. There's no other reminder.

That's about it for this letter. Shall close off now.

Sincerely,
George Chambers.

TORONTO TIMEX SINCLAIR USERS CLUB

May/June 1994

July 18, 1994

Dear Out-of-Town Members;

Well, I think the letter from Jeff Taylor, our Editor, at the beginning of this newsletter, sums things up pretty well. We have become long in the tooth, and, at least for my part, I want to move onto other things.

It may seem rather drastic to simply close up shop, but my feeling is that it is best to terminate cleanly. Then maybe if there is a wish on the part of some members they can reconstitute it in a different form. It did not seem practical to operate the club on the basis of an executive dispersed across the country.

We plan to put out a membership list with the next (last) issue, so that if users want to maintain contact with other members they will be able to do so. If you do not wish to be on this membership list, then do write and let me know.

Actually, I shall be maintaining my 2068 computer system for some time to come, and I can help any of you who run into a problem and need advice or help. So don't feel that you have been entirely abandoned!! Any of you into MSDOS?; drop me a line. I'm certainly interested in things MSDOS-wise. Programs and such like.

The real problem is what to do with all the Timex stuff I have collected over the years!! A great deal of it is printed material; magazines, books, photocopies, schematics, back issues of Sinc-Link. To say nothing about the hardware items!! I'll try to make a list for this newsletter. Interested? Seems too bad to chuck it out. We may offer to ship some of it to Don Lambert, TSNUG chief cook and bottle washer. That is, if he'll have it!!

My goodness, I am starting another collection of MSDOS and WINDOWS stuff; WORD, QBASIC, and all sorts of things.

One thing of interest is the Z80 Spectrum Emulator that I have loaded into the 486. It looks very interesting. There was an article about it in a recent SINC-LINK. I have sent away to get it registered, and I might have time for an article for the next newsletter. The registered copy has the capability of uploading Spectrum programs, (and saving them) from tape. Sounds challenging. We had an article about the emulator in the Sept/Oct 93 issue of Sinc-Link.

David Lasso has been working on Bill Jones' DAISY suite of programs. This is a set of interlinked Basic programs designed to make the 2068 more useful as a business application. David has been adapting it to the Larken Disk system; making it more efficient. It makes use of the Larken RAMdisk. He has sent me a copy for the club Larken Disk library. Anyone interested? Ask for a copy.

Shall close this off now,

Sincerely,

George Chambers.

Responded
8-2-94

MISC. PRINTED & PHOTOCOPIED MATERIAL

(free, but entice me to wrap and mail)

(this stuff is heavy, a looseleaf binder weighs about 2 lbs)

1. Folder on 3' AMDEK disk drives..Users manual and Technical manual.
2. Timachine documentation - Original
3. BEST OF CREATIVE COMPUTING Vol 1 1976 316 pages. Historical value only.
4. CP/M Primer. CP/M version 2.0. SAMS no date, but old. 92 pages
5. 2068/Spectrum ROM disassembly by Ray Byler. Sincus News.
6. Mscript manual. Three photocopies
7. Mscript manual Two original copies.
8. Pro/File manual, by Woods, Original copy.
9. Mfr/Dealer catalogues. A 3-ring binder. Of historical interest only.
10. Looseleaf binder on good Spectrum programming stuff.
11. Four looseleaf binders on good TS2068 technical stuff. Indexed.
12. Two looseleaf binders on good TS1000/ZX81 technical stuff.
- 13. One large loseleaf binder of Bill Jones UPDATE magazines.
14. Three TS2068 Technical manuals, photocopies.
15. One looseleaf binder on TS modems, including Smart Communications'' by Barry Carter
- 16. One large looseleaf binder of misc TS2068 harware articles.
17. One losseleaf binder on hacking Spectrum games.
18. One Novelsoft ZXPRT manual. Original
19. Four large Looseleaf binders of Spectrum game instructions, tips, etc.

8-2-94
request

BOOKS - TS2068/SPECTRUM

(Make an offer - I am easily tempted)

I have books!

1. Powerful projects with your Timex Sinclair - Jim Stephens - 227 pages.
T/S 2068 Basics and Beyond - Sharon Aker - 225 pages
2. The Timex Sinclair Explored - Tim Hartnell - 182 pages
4. Spectrum Interfacing and Projects - Graham Bishop - 136 pages
5. (Timex) Computer Interfacing techniques in Science - 224 pages
6. The ZX Spectrum-Your Personal Computer - 221 pages
7. 50 Programs for the T/S 2068 - Roger Valentine - 118 pages
8. 40 Best Machine Code Routines for the ZX Spectrum - 144 pages
9. Language Programming and Interfacing (all T/S machines) - 275 pages.
10. Inside the Timex Sinclair Computer - 114 pages
11. TS2068 Personal Color Computer - The TS2068 Users Manual - 290 pages.
12. 26 Basic Programs for your Micro (not computer specific) SAMS-174 pages
13. Color Graphics(for the TS2048 & 2068 computers) N. Hampshire 192 pages
14. Better Mchine Code & Better Basic - Ian Stewart & R.Jones - 188 pages.
15. Further programming for the ZX Spectrum - 163 pages
16. Spectrum Advanced User Guide - 230 pages
17. The Boots'' guide to the ZX Spectrum - Ian Sinclair - 118 pages.
- 18 Super Charge Your Spectrum - David Webb - 176 pages.
- 19 The Complete Spectrum ROM Disassembly - Dr Ian Logan - 235 pages.
(Magaz... nes such as SYNC, SUM, ZX COMPUTING, QL WORLD, etc.)

(Lots of ZX81/TS1000 books, also)

HARDWARE

- 1. 2 TS2068 Computers (working), a third one for parts.
2. 2 5 1/4'' drives, full-height, 80 tracks per side, 2 sides.
3. Commodore Joystick. can be used on 2068 LArken.
4. 2 cased keyboards - beautiful, can be wired up for TS2068 use.
5. Westridge modem, from Ed Grey surplus. In a case.
6. Power supply, very suitable for a Larken disk system.
7. ZX Printer plus paper.
8. Several ZX81's
9. Lots of other interesting stuff, ask me.